



MHT MOLD & HOTRUNNER  
TECHNOLOGY AG



The New Generation  
of our Vulcan II nozzle

# 20 Years Nozzle-Top-Technology

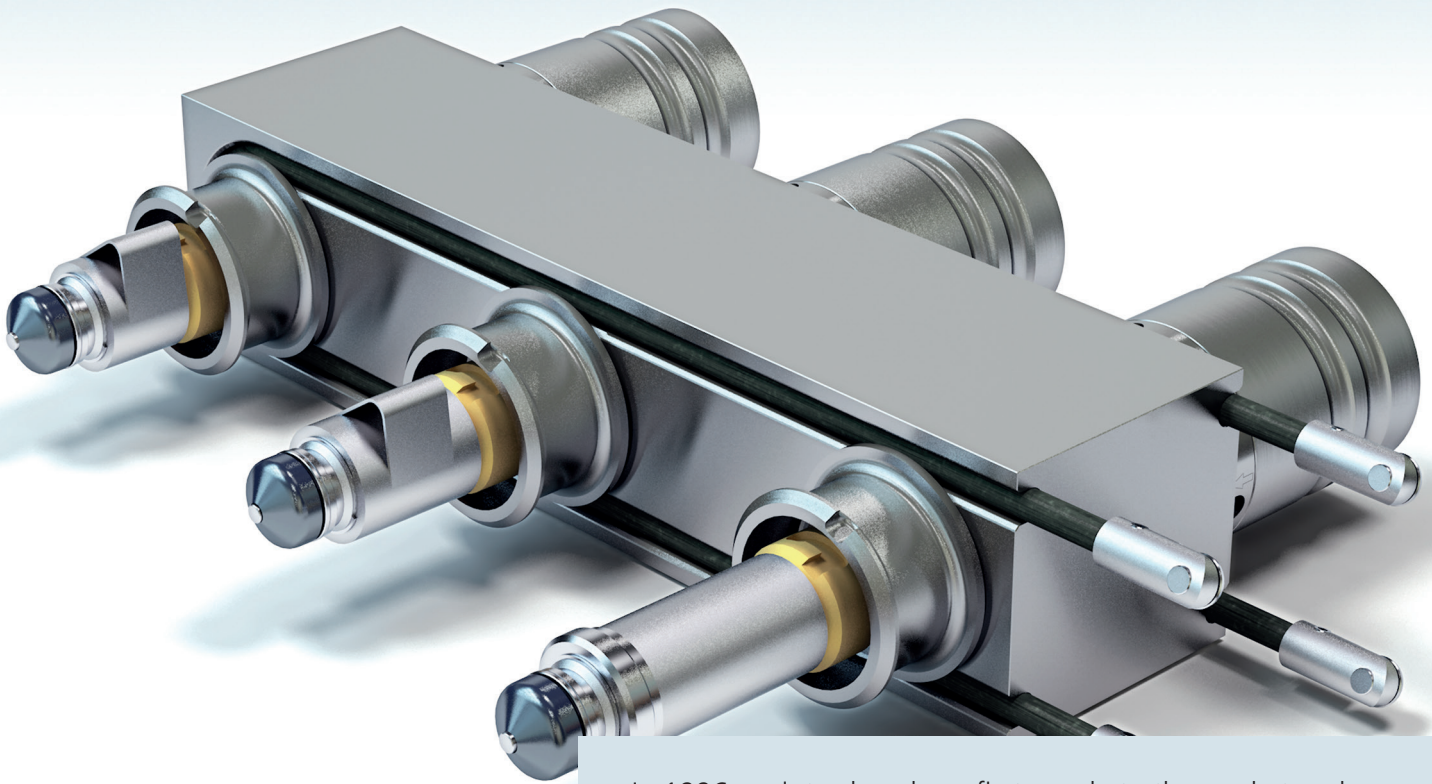

In 1996 we introduced our first nozzle to the market and followed in 2012 with the new Vulcan nozzle. Now, adapted to our customers' needs, we offer a new generation of nozzle with improved valve bushing and new piston – the Vulcan II nozzle.

## **New Properties and Components**

The new generation of Vulcan nozzles is distinguished by extended lifetime, ergonomic handling, reduced energy consumption, optimized parts for reduced maintenance and longer maintenance intervals.

Additional advantages are the new one piece cylinder and the two piece piston. This assures better assembling of all parts, no air leakage and no dust inside the piston.

## **New Actuator / Pneumatic Cylinder**

The new actuator allows quick and easy accessibility to all components. Valve stem changes and assembling of piston and cylinder with piston crown becomes very easy and convenient.

With this new design overstretching of the sealing ring is eliminated, heat transfer is reduced and lifetime for sealing elements is extended.

These new developments provide obvious advantages:

- reduced costs for air consumption
- reduced pump performance
- reduced costs for service intervals
- no leakage issues

## **New Nozzle Tip**

Accessibility by cavity plate removal in the machine is quick and easy.

Nozzle tip inlay provides direct heat transfer to nozzle tip. New insulation ring for reduced heat losses, disassembling of TC and heater is simple.

## **Advantages:**

- reduced costs for maintenance
- different materials for nozzle tip available
- reduced heat loss to the environment
- efficient heat utilization
- reduced energy costs
- reduced costs for preform production

If you wish to know more about our new Vulcan II nozzle or are interested in a personal consultation, please refer to the following address and contact info:

## **MHT Mold & Hotrunner Technology AG**

Dr. Ruben-Rausing-Straße 7  
65239 Hochheim/Main  
Phone: +49 (0) 61 46 906-0  
info@mht-ag.de